

THANK YOU!

You have successfully downloaded your **FREE** PlansNOW.com woodworking article.

► [Go to Page 1](#)

► [Got to PlansNOW](#) and save 20% with coupon code **SPRING**

Tips for Trouble-Free Printing

► **Clear printer memory.** If you are unable to print this document, turn off your printer for at least 15 seconds and try again.

► **Get advanced printer help.** Visit [Adobe Support](#) for instructions in troubleshooting common printer problems. www.adobe.com/support/techdocs/150d6.htm

SAVE 20%

As a PlansNOW member, you'll SAVE 20% on every downloadable plan we offer!



[Playhouses & Sheds](#)
Everything you'll need for a kid's summer entertainment.



[Outdoor Furniture](#)
Easy-to-build projects using a minimum of power tools.



[Gazebos & Arbors](#)
Make outdoor living more enjoyable this summer!

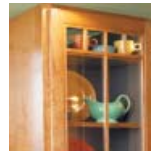

[Home Improvement](#)
Save hundreds of dollars in remodeling when you DIY.



[Bedroom Furniture](#)
Beds, dressers, armoires, cribs, cradles, and more!



[Shop Jigs & Techniques](#)
Get the most from your tools with easy-to-build shop jigs.



[Craftsman Furniture](#)
Build the same distinctive features from the early 1900s.



[Workbenches & Tool Stands](#)
Sound woodworking starts with a solid workbench.

20% OFF Coupon Code for March 2005: [SPRING](#)



Need Hardware? [Woodsmith Project Supplies 1-800-444-7527](#)

For plans that require unique or hard-to-find hardware and accessories, we may have a kit available for purchase.

Contact Us. Have a question about PlansNOW? We want to hear from you!

E-mail: ► planman@augusthome.com Phone: ► 1-800-333-5441 (Mon-Fri 8-5 Central time)

5 minor repairs for Major Mistakes

Mistakes happen. And when they do, you have to deal with them. Here's a look at some quick and easy fixes for five common woodworking goofs.

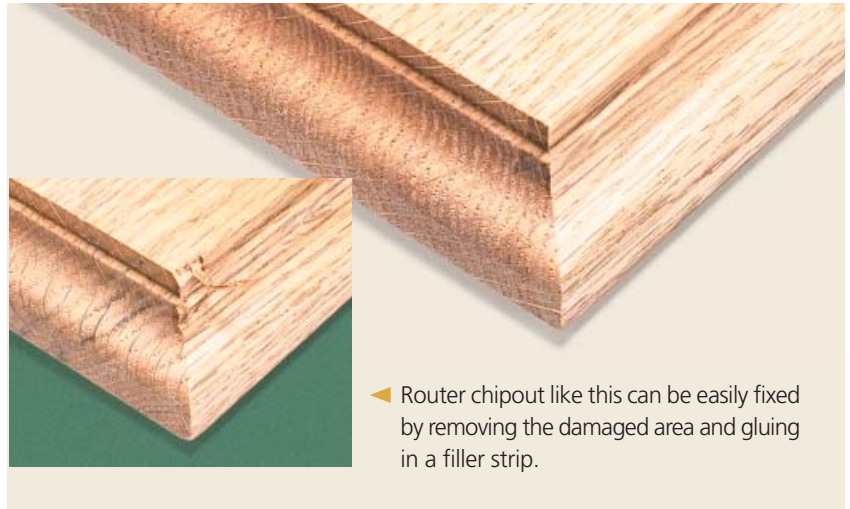

◀ Router chipout like this can be easily fixed by removing the damaged area and gluing in a filler strip.

1 Router Chipout

There are few things more frustrating than routing a profile on the edge of a workpiece only to have a sliver of wood blow out. Fortunately, there's an easy fix.

All you have to do is rout a rabbet along the edge of the profile to

removed the damaged area (Step 1). Then glue a slightly oversized filler strip of matching wood into the rabbet (Step 2). After planing or sanding the filler strip flush with your workpiece, you can rout a new profile along the edge.

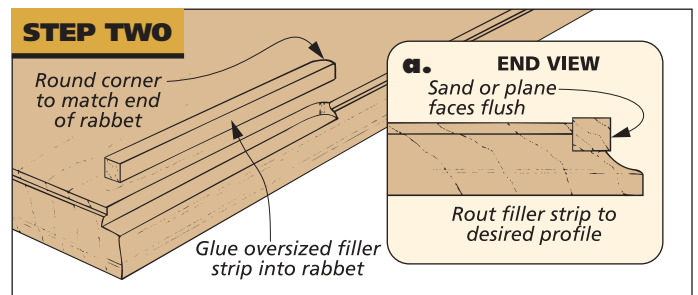
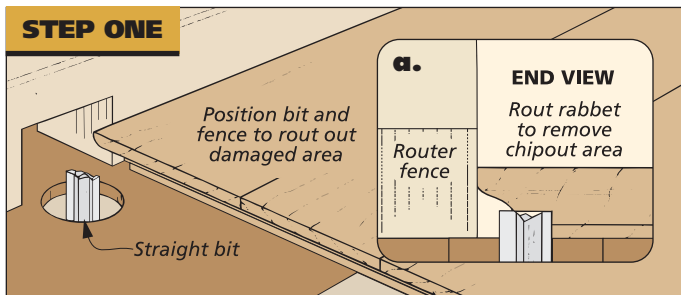

2 Moving a Hole

Drilling pilot holes for hinges screws is not one of my favorite chores. No matter how hard I try, it seems like there's always at least one hole where the drill bit drifts off its mark. When this happens, the best

solution I've found is to "move" the hole.

This might sound impossible, but if you take a look at the drawings below, you'll see how easy it really is. All you have to do is drill out the offending hole

with a larger-diameter drill bit. (A Forstner bit works best.) Then glue a face grain plug into this hole. Finally, lay out the correct location for the pilot hole and re-drill the hole.

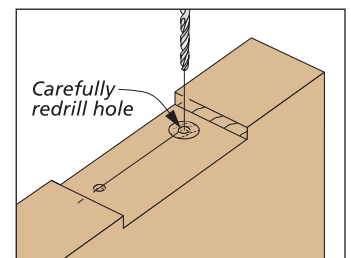
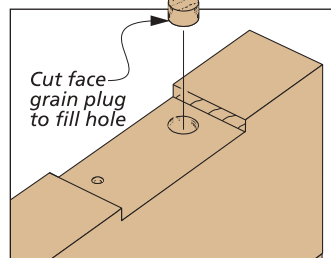
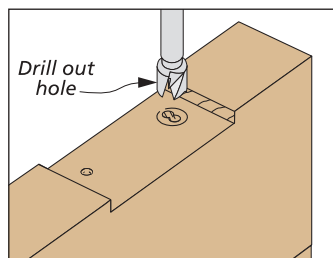
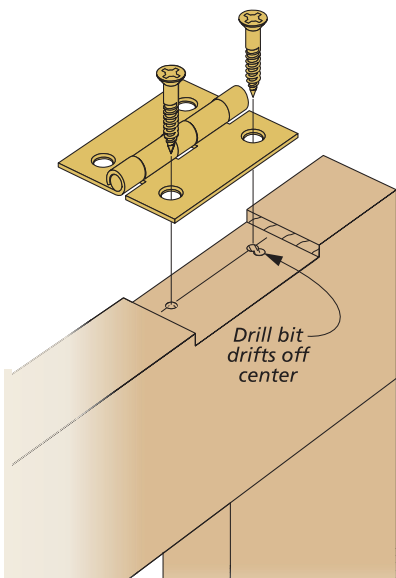

3 Misplaced Mortise

There are few mistakes in woodworking that can make you feel as foolish as making a mortise in the wrong spot on a workpiece. If you have extra stock, it's probably easier to make a new part. But if you're working on something more substantial (like a heavy table leg) making a new piece may not be an option.

In this case, the next best solution is to "patch" the mortise. The process is really pretty straightforward. Start by cutting a wood plug to fit in the mortise. After gluing it into the mortise, trim $\frac{1}{8}$ " off the face of the workpiece. (The face with the mortise.)

Next, cut a facing out of some $\frac{1}{8}$ "-thick stock and glue it to the workpiece. (Try to match the facing to the color and grain of the workpiece as close as possible.) After trimming the facing flush with the workpiece, you can lay out the mortise in the correct location.

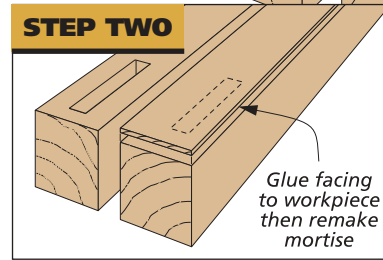
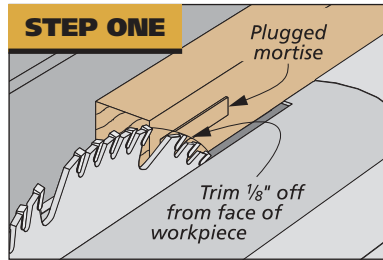

▲ Plugging a misplaced mortise allows you to salvage a workpiece.

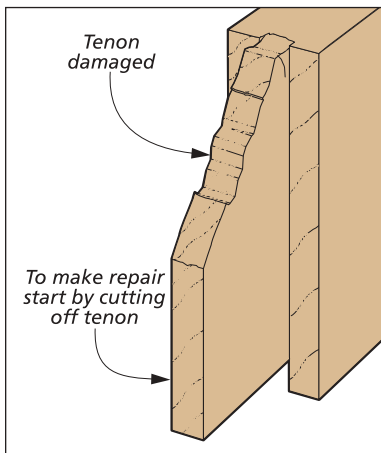

Half Lap. You can repair a damaged tenon by trimming it off and gluing on a new piece of wood to the end of the workpiece.

4 Damaged Tenon

It's not only mortises that can give you problems. Sometimes, a tenon can snap off while you are making a dry run to test the fit. Here again, making an entirely new replacement piece may not always be the best option. In this case, you can recut the tenon by gluing on a new "end" to the workpiece.

To do this, start by trimming off the damaged tenon at the shoulder. Then cut a slot in the end of the workpiece as shown in the drawing at right. (This slot should be at least 1" deep.)

Next, cut a tongue on the end of a

scrap piece of stock to fit in the slot in the workpiece. After gluing the scrap piece into the slot, you can go ahead and recut the tenon.

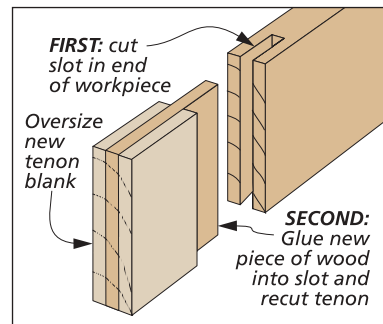

5 Open Miters

Miter joints are notoriously tricky when it comes to getting a tight fit without any gaps. This next tip has saved me on more than one occasion.

If you have a miter joint that is open just slightly, try "burnishing" it closed. All you have to do is take a burnisher (I use the round shank of a screwdriver) and run it across the edge of the open miter (from bottom to top), as in the drawing at right.

The burnisher closes up the joint by "rolling over" the mitered ends of

the workpieces. Once the project is finished, you'll probably be the only one that will know there was ever a problem to begin with.

Note: This tip works well on miters that are off just slightly ($\frac{1}{32}$ " or so). If you have a miter with a larger gap, you're better off cutting through the joint and re-gluing the pieces. **W**

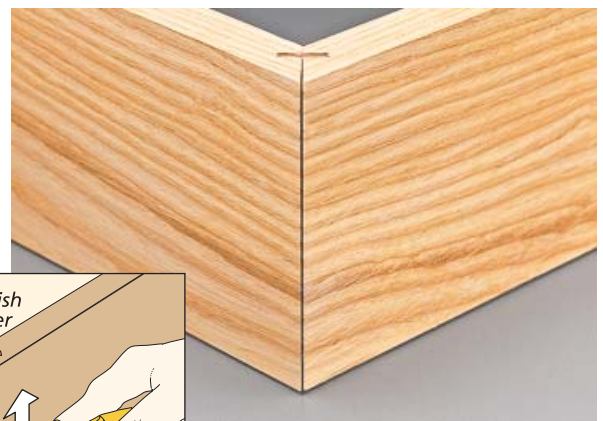
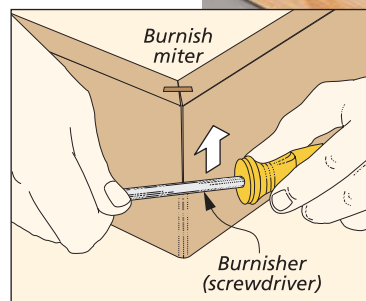

▲ Open miters like this are a common problem. Burnishing the miter closes up the gap and makes the joint nearly invisible.