

THANK YOU!

You have successfully downloaded your **FREE** PlansNOW.com woodworking article.

▶ [Go to Page 1](#)

▶ [Go to PlansNOW](#) and save 20% with coupon code **FASTENER**

SAVE 20%

As a PlansNOW member, you'll **SAVE 20%** on every downloadable plan we offer!



Bedroom Furniture
Beds, dressers, armoires, cribs, cradles, and more!



Shop Jigs & Techniques
Get the most from your tools with easy-to-build shop jigs.



Craftsman Furniture
Build the same distinctive features from the early 1900s.



Workbenches & Tool Stands
Sound woodworking starts with a solid workbench.



Playhouses & Sheds
Everything you'll need for a kid's summer entertainment.



Home Improvement
Save hundreds of dollars in remodeling when you DIY.



Gazebos & Arbors
Make outdoor living more enjoyable this summer!



Outdoor Furniture
Easy-to-build projects using a minimum of power tools.

Mitered Half Lap

Here's a straightforward table saw technique for super-strong miter joints.

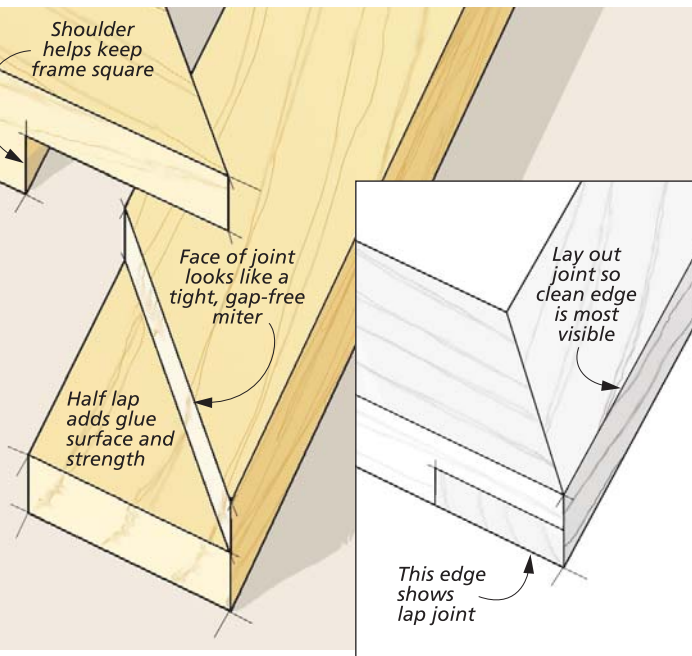

Tight-fitting miter joints are a hallmark of great craftsmanship. The trouble is even the most flawless miter isn't a very strong joint to use — especially in a door.

When it comes down to it, a miter joint isn't really much more than a butt joint. The good news is, there's a "hybrid" joint that combines the look of a miter with the strength of a half-lap joint.

HOW IT WORKS. You can see how this joint fits together in the drawings above. The front face looks like an ordinary miter. On the other side of the frame

are the joint lines and square shoulders you'd find in a half lap. What this gives you is extra, long-grain glue surface. This reinforcement makes the joint the perfect candidate for small cabinet doors and frames.

THE RIGHT ORIENTATION. As you'll see, cutting this joint on the table saw isn't difficult. But there is one thing to think about before you use it — the orientation. Two opposite sides of the frame have clear edges that look clean (inset above). The other edges show the end grain of the crossing piece. So what I like to do is orient the parts so that these edges are least notice-

able. For example, on a door, the sides are usually the most visible. That means I'd make the joint so the lapped edges are on the top and bottom.

GETTING READY. There are just a couple of other things to talk about before getting started. The first is that it's a good idea to have a few test pieces on hand. These will come in handy for setting up the saw for each step in the process.

Second, the key to cutting an accurate joint is the simple sled shown in the box on the next page. The sled rides along the rip fence and has a pair of fences to guide the workpieces across the blade.

ONLINE EXTRA
video workshop

You can see how to cut a mitered half lap on the table saw at: www.woodsmith.com

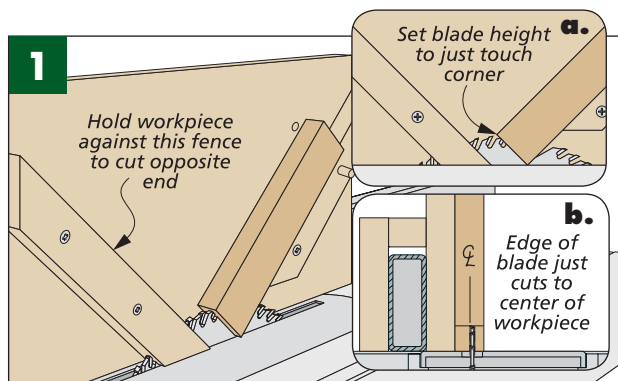
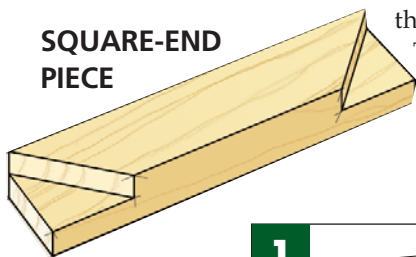

Angled Kerf. The first step is to cut a kerf along the center line of the workpiece. Use the rear fence to cut one end and the front fence to cut the other end.

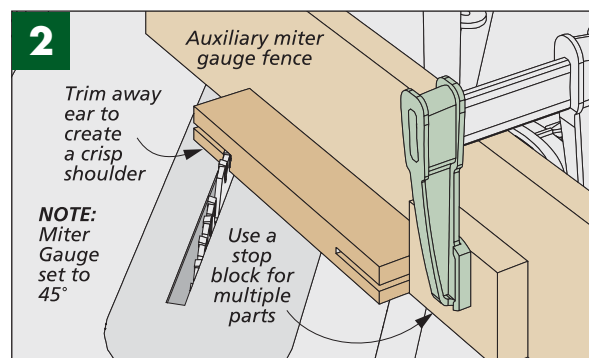

Trimming the Ear. Remove the thin "ear" from the workpiece by cutting along the end of the kerf. A stop block keeps the workpiece from creeping.

CUTTING THE JOINT

As you cut the joint, what you're really doing is making two sets of parts — a square-end set and a mitered-end set.

SQUARE-END PIECES. I like to start by making the square-end parts. The reason is they're the simplest of the two to make — they require only two steps, as you can see in the drawings on page 1.

ANGLED KERF. There are only two things to keep in mind here. The first is the height of the saw blade. It should match the height of the corner of the workpiece (Fig. 1a).

The second thing is the rip fence position. The distance from the sled side to the blade should be exactly half the thickness of your stock, as in Fig. 1b. Here's where you'll put your test pieces to use.

Once you have everything set, you can cut a kerf in one end of each piece using the rear fence. Making the kerf in the opposite end is simply a matter of repeating this step with the workpiece held against the front fence. (Be sure to keep the same face of the workpiece against the side of sled during each cut.)

Before going on to the second (and last) step in making the square-end parts, I want to point out one thing. While you have everything set up, now is a good time to make the sled cuts on the mitered parts, as in Fig. 3. This will save you some hassle trying to get the saw and sled reset later on.

TRIM CUT. Like I said, there's just one step left to finish the square-end pieces. And that's to cut away the thin "ear." You can see how I do this

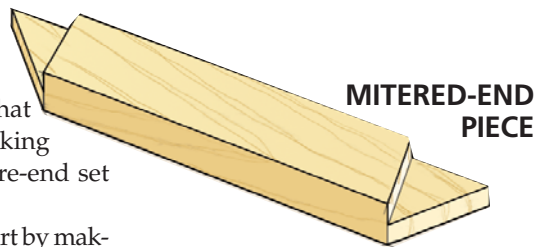

MITERED-END PIECE

in Fig. 2 on page 1. The important thing to think about here is to make sure you're cutting on the correct side of the workpiece.

MITERED PIECES. After completing all the cuts on the square-end parts, you can get to work on the mitered-end pieces. For these parts, it'll take three steps to get the job done. Like the other half of the joint, the first step is to make a kerf in each end using the sled. But instead of the workpiece being angled, it's held vertically, as in Fig. 3 above.

From there, you can take the sled off the saw and use the miter gauge to make the remaining two cuts. A look at Fig. 4 shows how to make the first cut with the miter gauge square to the blade.

MITER THE ENDS. The final step is to flip the piece over and miter the ends, as illustrated in Fig 5. Set the miter gauge to 45° and miter one end of each part. Then rotate the miter gauge over to the other 45° setting to cut the remaining ends. Like before, if you have a lot of parts to make, a stop block will come in pretty handy.

ASSEMBLY. Once all the parts are cut, you're ready for assembly. And here's where you'll discover another benefit of the joint. The square shoulders on the mitered pieces allow you to tighten a clamp across the joint for a snug, gap-free fit. **W**

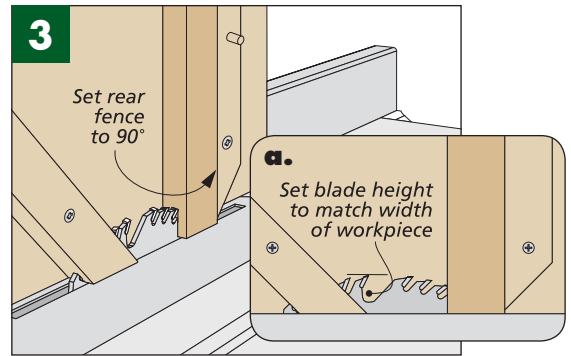

3 **Vertical Cut.** Using the same sled position as before, rotate the rear stop so that it's vertical to cut a straight kerf.

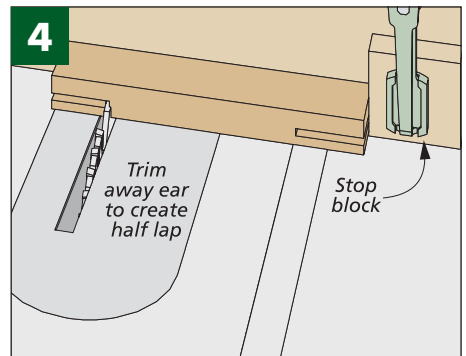

4 **Trimming the End.** With the miter gauge square to the blade, cut away the waste to create a half lap on each end.

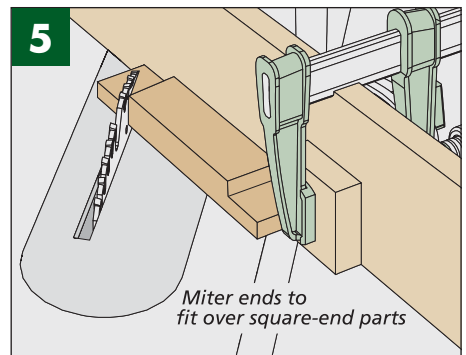

5 **Miter Ends.** The last step is to miter each end of the workpiece. Once again, sneak up on the cut for a perfect fit.

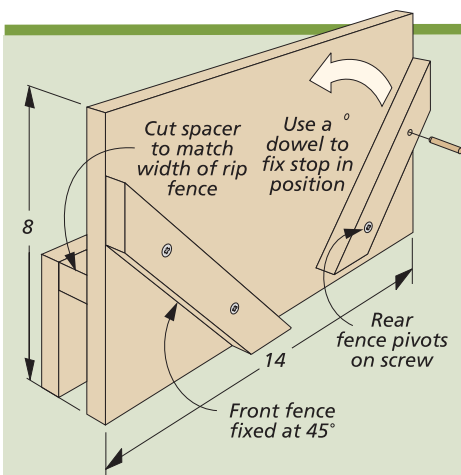

How-To: Make the Sled

Since half of the cuts are made with the workpiece held on end, I needed a way to hold it securely and at the correct angle. So I came up with the simple sled you see in the drawing at left.

The sled is designed to ride along the rip fence of the table saw. The tall fence keeps the workpiece from tipping while it's being cut. Then to hold the workpiece at the correct angle, I added a pair of fences.

The front fence is fixed at 45° and is used only for cutting the square-end pieces. The rear fence pivots between two positions — 45° and 90°. To provide enough clearance to pivot, the rear fence is trimmed short of the sled bottom.

There's one other thing that I should mention. When building the sled, be sure to locate the screws so they won't come in contact with the saw blade.